



ALTRAX

Conveyor Belt – 3m Manual

For Assistance: Altrax

Mon – Fri 9am – 5pm
(03) 9808 9448



9 Milgate Street,
Oakleigh South, 3167

(03) 9808 9448

info@altrax.com.au

INDEX

EC DECLARATION OF CONFORMITY 3

USER INSTRUCTIONS 4

1. PURPOSE AND USE 5

2. AREA OF APPLICATION 5

3. DEPLOYMENT OPTIONS 5

4. ENTRY INTO USE 6

5. PERIODIC INSPECTION AND CLEANING 9

6. REPLACING COMPONENTS 9

7. TRANSPORT AND STORAGE 11

8. GENERAL SAFETY INSTRUCTIONS 12

9. SAFETY INSTRUCTIONS FOR HIRERS 12

10. USER INSTRUCTIONS FOR HIRERS 13

DEPLOYMENT DIAGRAM (figure 5) 14

DIAGRAMS OF ACCESSORIES 14

3-METRE MINI-MAXI 230V – PARTS LIST 15

GENERAL ASSEMBLY PLAN CONVEYOR BELT 16

SWITCHBOX DIAGRAM 18

ACCESSORIES DIAGRAM 18

ELECTRICQL CIRCUIT DIAGRAM 19

EMERGENCY STOP DIAGRAM 20

EC DECLARATION OF CONFORMITY

Etramo Bvba
Vosveld 20
2110 Wijnegem
Tel.: 32/(0)3/326.02.92.
Telefax: 32/(0)3/327.31.80
Email: info@etramo.be

**EC declaration of conformity of a machine with the machinery directive (2006/42/EG)
and the provisions implementing it in national legislation.**

The manufacturer: **Etramo bvba**
 Vosveld 20
 2110 Wijnegem
 Belgium

Hereby declares that the machine:

Conveyor belt

Type: **Mini-Maxi**
Serial number: **3S**
Of manufacture: **2016**

Fulfils the provisions of the European machinery directive (2006/42/EG) and the provisions to implement it in national legislation and EMC directive 2004/108/EG.

At Wijnegem
01/01/2016



Johnny Vancraybex
Business Manager

**CONVEYOR BELT
MINI-MAXI
3-METRE STEEL
230V**

1. PURPOSE AND USE

The conveyor belt has been designed to transport solid (non-liquid), non-dangerous materials such as sand, gravel, rubble, agricultural crops, etc.

The material being moved must be loaded on the conveyor belt with a sense of professional skill so that no damage is caused by overflowing.

A maximum of 6 conveyor belts of 3 meters can be linked in series on one 220V - 16A power supply (figure 5).

A large hopper is placed on the first conveyor belt (figure 1). This keeps the deposited material on the belt.

Each conveyor belt is held up by a trestle support (figure 3) or a set of pipes. Supporting pipes are provided in the frame for the assembly of a set of pipes.

2. AREA OF APPLICATION

The conveyor belt can be used in roofed areas as well as outdoors in humid environmental conditions.

3. DEPLOYMENT OPTIONS

The conveyor belts are separate from each other and can be deployed in series.

They must be deployed in a way that ensures they cannot shift, i.e. the chair or pipes construction must stand on a solid foundation.

The conveyor belt cannot be supported by the small hopper.

In the longitudinal direction they can be placed at any angle to the previous conveyor belt.

The conveyor belt must always be filled via the large hopper, i.e. items must never be filled directly onto the belt.

The conveyor belt must always be level in the width direction. This is to prevent the belt from slanting.

The rubber belt must be able to run unimpeded on the underside of the conveyor belt without touching the ground or any other obstacle. It must be absolutely avoided that anything falls in between the rubber conveyor belt.

The following deployments are possible:

1. Deployment in a straight line and deployment on a slope in series (figure 5).

The conveyor belts cannot be placed on top of each other. The conveyor belt sits on the ground on the filling side. At the output side, the conveyor belt sits on a chair, set of pipes or (for example) a container. The conveyor belt is positioned in such a way that the output of the material ends up in the small hopper (fig.2).

The gradient depends on the type of the materials being transported and their weight.

2. Deployment where the conveyor belts are not placed behind each other.

The conveyor belts can be deployed and arranged at every angle.

The conditions for deployment are the same as in point 1.

!! Important: Read all of the information stickers on the machine very carefully.

Please refer to the next chapter 'Entry into use' for information on linking several conveyor belts.

4. ENTRY INTO USE

When using the conveyor belt for the first time, it might need to be adjusted. (See paragraph 6.4)

Each conveyor belt is supplied with a power cable that enables the user to connect the device to the 230V mains network.



Power cable

The consumption per conveyor belt is 2.3 A.

If the conveyor belt is overloaded the motor stops thanks to the built-in thermal fuses in the motor and switch unit.



It is advisable to start the conveyor belt unloaded to prevent the thermal fuses on the motor and/or switch from triggering.

In certain circumstances (non-overloaded belt and small slope), the conveyor belt can nonetheless be started while loaded.

Warning!!! : If the belt does not start to move, switch off the motor immediately.

Linking several conveyor belts.

When the conveyor belt enters service the user must ensure that the leads cannot be damaged. A maximum of 6 conveyor belts of 3 meters can be connected behind each other using a secured 16 A mains power supply. The conveyor belts can be coupled via a linking lead so that a separate power supply (220V) does not have to be provided for each belt.

The last conveyor in the series must be equipped with an end plug.



If the user wishes to use more than 6 belts, a separate mains power supply must be provided for every 6 conveyor belts.

Each conveyor belt can be started separately by using the start button. The start button is green in color. A red (emergency) stop button is located at the end sides of the conveyor belt.

'Stop' not only halts the conveyor belt on the machine where the stop button was pressed but also all conveyor belts that are connected to the same power supply.

!!! Only switch on live power to the conveyors when ALL conveyors have been fully set-up and electrically connected.

!!! Never connect/disconnect or clean conveyors that are attached to live power.

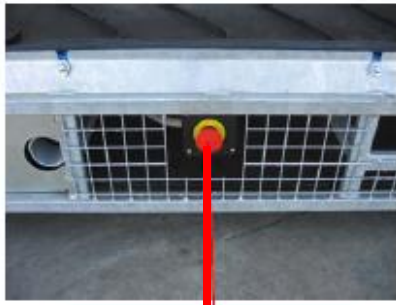

Emergency stop



Start

Stop



Connecting cable

When restarting the conveyor belt, the various conveyor belts all have to be started up separately.

Always start the last one in the series first.

Installation of a large hopper (figure 1)

A large hopper is placed at the start of the first conveyor belt (figure 5).



Installation of a small hopper (figure 2)

A small hopper is fitted on the piling-up side of the conveyor belt above the support groove (figure 5).



Support groove

5. PERIODIC INSPECTION AND CLEANING

See assembly plan (page 17)

1. Inspection

The driving roller, accompanying roller and trough rollers must be checked regularly and cleaned if necessary.

It is very important for no material residue to be left behind on the roller. Conveyed material that gets stuck between the roller and belt can be very damaging and can lead to the system breaking.

Also inspect the operation of the belt scraper regularly.

2. Cleaning

The conveyor belt can be rinsed with a water hose (maximum pressure: 5 bar)

!! Important: Caution is advisable when performing the task

Uncouple the conveyer belt from the power supply

Do not aim the water hose directly at the electricity box.

Never scrape the belt or drums with your hands or sharp objects.

6. REPLACING COMPONENTS

See assembly plan (page 18)

Replacing the rubber belt

1. Dismantling the rubber belt

Method and sequence:

- Detach bolts no.6.
- Remove intermediate part no.5 at the front of the conveyor belt.
- Detach the cover plates no.18
- Remove belt scraper no.9 by pulling it over the hinge points (side by side).
- Loosen nuts no.14 and remove supporting roller no.16.
- Unblock nuts no.3 and take the depth at which bolts no. 4 are screwed in as the reference measurement.
- Loosen bolts no.4 (fully).
- Lift the accompanying roller out of the groove (upwards) and take it out of the frame.
- Hook the belt above the guidance grooves.
- Take the rubber belt away, starting with the driving roller.
- **!! Important: Make sure that the driving roller does not move out of the slides**

- Ensure that the motor cable is lying in the safety groove

2. Assembling the rubber belt

Method and sequence:

- Assemble the belt in the reverse order to dismantling.

3. Adjusting the rubber belt for tension

Method and sequence:

- Screw bolts no.4 tight alternately until the tightening depth is reached!

4. Adjusting the rubber belt for parallelism

Method and sequence:

- If the belt runs against the frame on one side, tighten screws no. 4 by a ¼ turn at the side where the belt touches the frame (or loosen the screws on the opposite side).
- Allow the belt to turn by a few belt lengths and check it in the meantime.

!! Warning: Caution is advisable when performing the task. This work can **NEVER** be done while the conveyer belt is running or electronically powered. Avoid accidents!

!! Important: - Never replace parts when the belt is electrically powered.

- Only use original components at replacement.
- Replacements or repairs other than those listed in these user instructions (especially the electrical aspects) can only be executed by technically competent staff.

7. TRANSPORT AND STORAGE

1. Transport (Transportability)

Two people can easily move the conveyor belt. To do this use the specially designed wheel system (see figure 6). These carrying wheels are a handy means of transport, even on uneven ground.

Using the Wheel system:

Lift up the conveyor belt on the side where the wheel system is being mounted (See fig. 6-A) and fit the wheel system into the opening provided (fig. 6-B).

The conveyor belt can now be lifted on the other side and moved along.



2. Storage

A maximum of 6 conveyor belts can be placed above each other.

When stacking, the semi-circular support rings are placed in the grooves on the conveyor belt lying beneath (figure 4).



8. GENERAL SAFETY INSTRUCTIONS

!! Important:

- **People cannot ‘hitch a ride’ on the Mini-Maxi in any circumstance.**
Keep children away.
- **If the Mini-Maxi is deployed at a height, all precautions must be taken to prevent conveyed material from falling out (e.g. onto staff).**
- **The Mini-Maxi can never be deployed in a position where the electrical contacts are underwater.**
- **If the deployed installation becomes blocked during use, all conveyor belts must be halted before the cause is removed.**
- **Never work on the conveyor belt while it is electrically powered.**
- **The conveyor belt can be rinsed with a maximum water pressure of 5 bars.**

9. SAFETY INSTRUCTIONS FOR HIRERS

To ensure safe, correct use of the machine, you must read this text thoroughly in advance.

Do not allow the conveyor belt to be used by minors or unauthorized persons.

Keep other people at a distance and never leave the conveyor belt unsupervised.

Children or anyone else can never ‘hitch a ride’ on the conveyor belt in any circumstance.

Only use the conveyor belt for materials that are not harmful or dangerous.

Never transport materials that could adversely affect or damage the conveyor belt.

Load the material on the conveyor belt in a way that ensures nothing can fall off over the side.

Start the conveyor belt unloaded to prevent the fuses from switching off the power.

If the machine is overloaded the thermal fuse switches the motor off. Wait for some time. The conveyor belt can only be restarted with the start button when the fuse has been restored to its original state.

Stack a maximum of 3 conveyor belts on top of each other during storage or transport.

10. USER INSTRUCTIONS FOR HIRERS

The conveyor belts can be set up behind each other. Begin at the end point and install a small hopper. Put the end of the next conveyor belt above it with a chair construction that sits on the ground. Ensure that it is deployed in a stable way. Also ensure that the conveyor belts cannot shift.

Equip the first belt with the large filling hopper, especially on a steep slope.

When deploying on a slope the conveyor belts must be supported separately with a sturdy pipe construction.

Build the construction based on the pipe provided in the frame.

Ensure that the conveyor belts themselves can always run unimpeded on their underside without touching the ground or another obstacle.

The conveyor belts can only be deployed at an angle in the longitudinal direction. In the width direction they must always be level to prevent the belt from slanting.

The gradient is limited by the type of material being transported and its weight.

The conveyor belts can also be deployed in a falling line.

Connecting leads are used for coupling. Ensure that these cannot be damaged or dragged along.

Only use the electrical lead of the belt itself in dry weather conditions. If the conveyor belt is used in humid conditions connect the electricity directly to the built-in socket. During set-up prevent electrical parts from being able to slip underwater. Connect a maximum of 6 conveyor belts electrically on a 16 A power supply.

Use extension leads (minimum 2.5 mm²) with an earth and always roll them out in full. Always ensure that the power supply is equipped with a differential switch and an earth leak switch.

The conveyor belt is activated by using the green start button. The red button halts the belt of all conveyor belts that are connected to the same power supply.

After the electricity is switched off, the machine is to be rinsed with a water hose and thoroughly cleaned.

DEPLOYMENT DIAGRAM (figure 5)

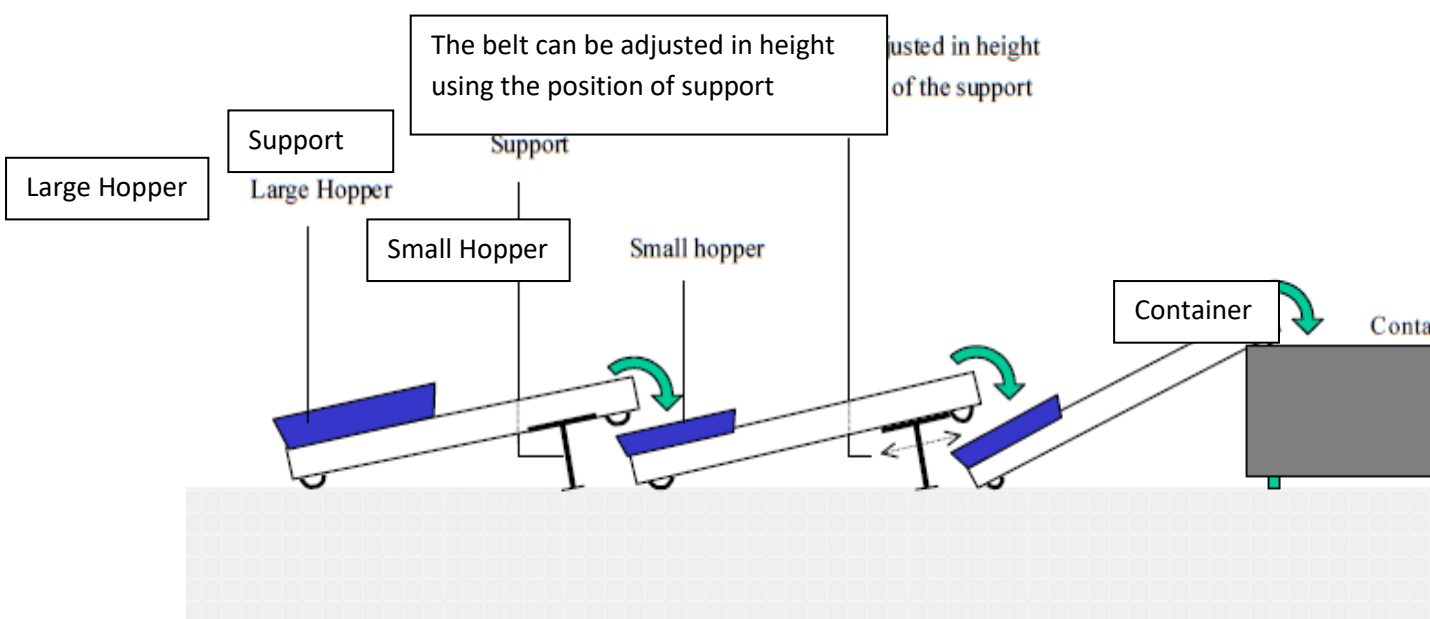

DIAGRAMS OF ACCESSORIES

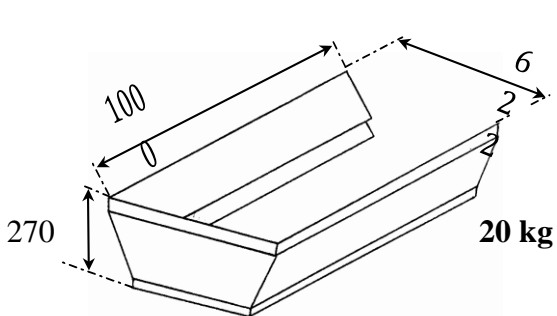

Large Hopper – Fig. 1

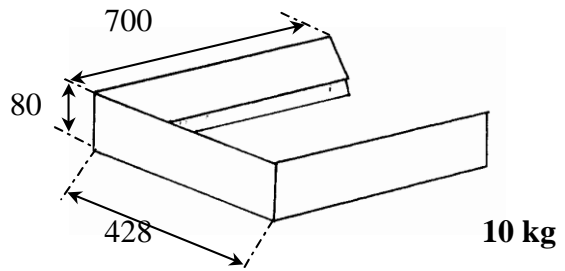

Small Hopper – Fig. 2

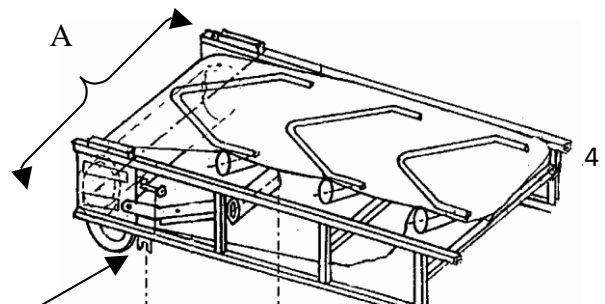
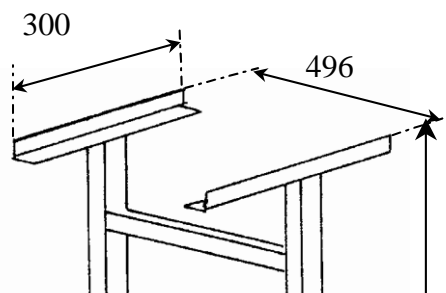

475

B

4,10 kg

3.2 kg

686

Support – Fig. 3

Transport wheels – Fig. 6

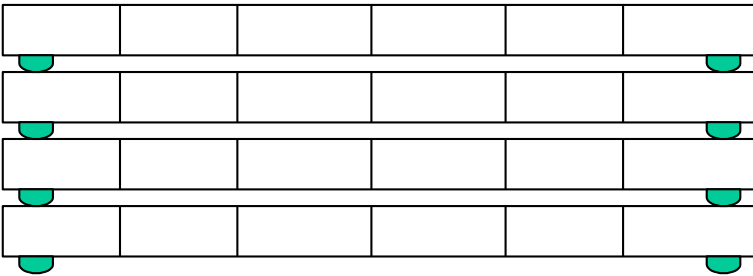

Stacking – Fig. 4

3-METRE MINI-MAXI 230V – PARTS LIST

Part.Nr.	Nr. Art.	Description	Page	Nr
	01815	Complete steel 3 m conveyor belt - 6P		
1	00801	Square frame stop - black	18	8
2	00711	Return roller type D	18	1
3	00070	6-sided nut M10	18	4
4	00663	6-sided tap bolt M10x110	18	4
5	00831	Intermediate part	18	1
6	00556	Six-sided top bolt M8x20	18	4
7	00482	Six-sided nut M8	18	4
8	01657	Wheel system sticker 50kg	18	2
9	00853	Complete belt scraper	18	1
11	00544	Turning direction sticker	18	1
12	01807	6 pole socket outlet	18	1
13	00886	Trough roller	18	12
14	00781	Low six-sided nut M12	18	28
15	00136	Flat closing ring M12	18	16

16	00733	Support roller	18	1
17	01710	Emergency stop	18	1
18	03228	Cover plate (set comprising 4 items)	18	1
19	00885	Complete frame - 2mm	18	1
20	00396	Sticker 230V	18	1
21	01808	Switch box model 2007 - 230V - 3A	18	1
22	00710	Capacitor 20mf	18	1
23	00683	Switchbox aluminium bridge	18	1
24	00543	User instructions sticker	18	1
25	00399	Identification plate	18	1
26	00712	Motor 230V - 0,37KW	18	1
27	01842	Stop button red	19	1
28	01810	Start button green	19	1
29	01933	Thermal fuse 3,0A	19	1
30	00610	Cap thermal fuse	19	1
31	01811	6-Pole socket outlet switchbox	19	1
32	01812	6- Pole end plug	19	1
-	00393	Sticker CE	-	1
-	00808	Rubber - conveyor belt 3 meter	-	1
33	00810	Complete large hopper	19	1
34	00786	Rubber side - large hopper	19	2
35	00843	Rubber back side - large hopper/small hopper	19	1
36	00856	Complete small hopper	19	1
37	00843	Rubber back side - small hopper/large hopper	19	1
38	00844	Rubber side - small hopper	19	2
39	00862	Transport wheels	19	1
40	00860	Trestle support	19	1
41	01813	Power cable model 2007	19	1
42	01814	Connecting cable model 2007	19	1

GENERAL ASSEMBLY PLAN CONVEYOR BELT

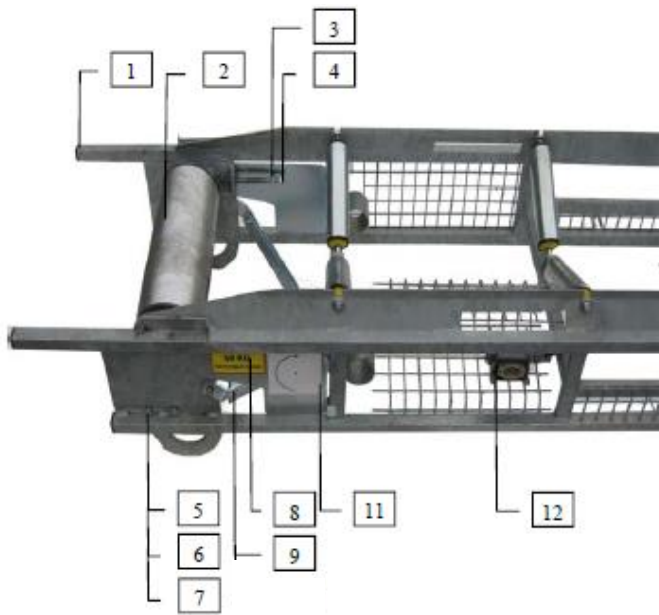

**RETURN ROLLER
SIDE
CONVEYOR BELT**

**MIDDLE
CONVEYOR BELT**

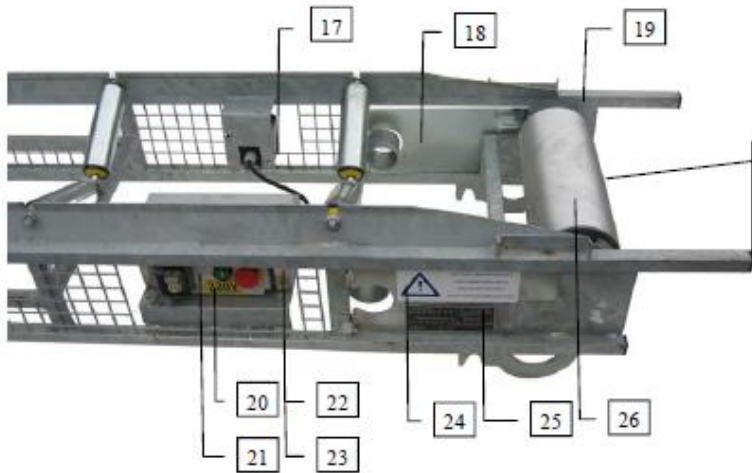
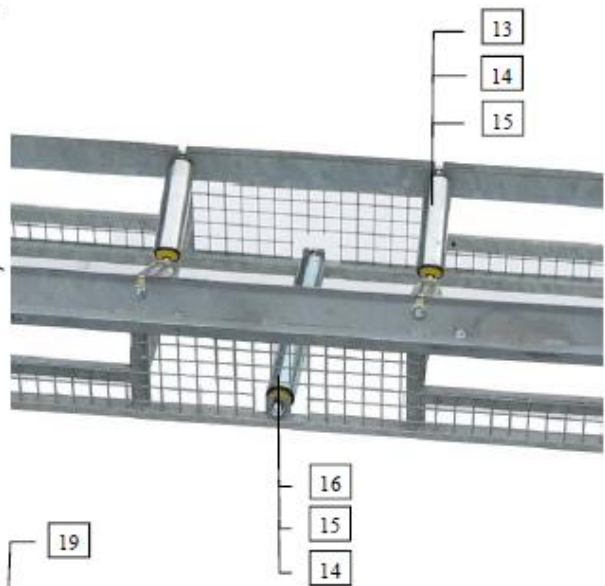

**MOTOR SIDE
CONVEYOR BELT**

SWITCHBOX DIAGRAM

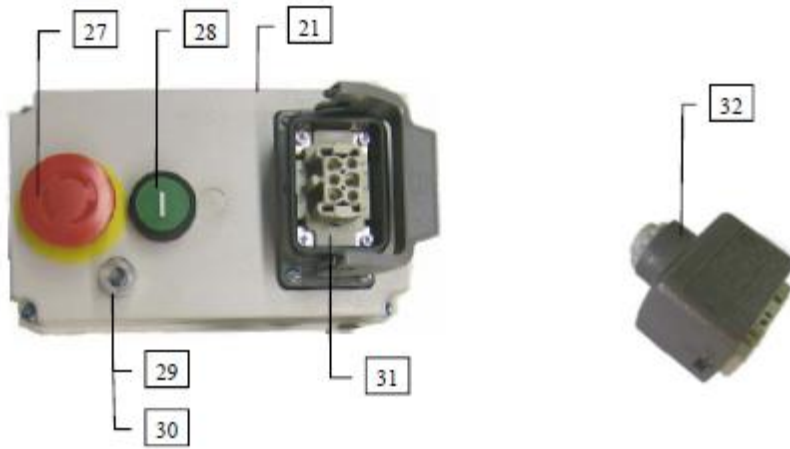

ACCESSORIES DIAGRAM

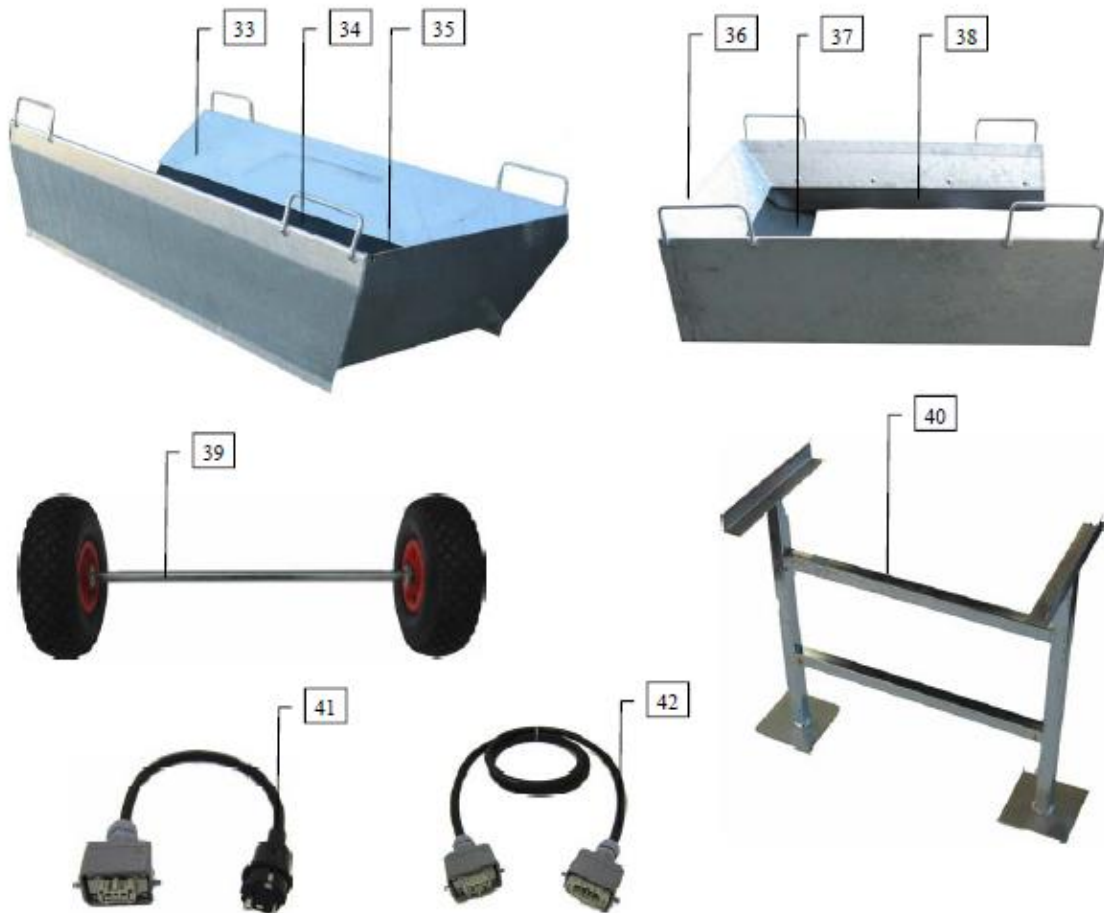

ELECTRICAL CIRCUIT DIAGRAM

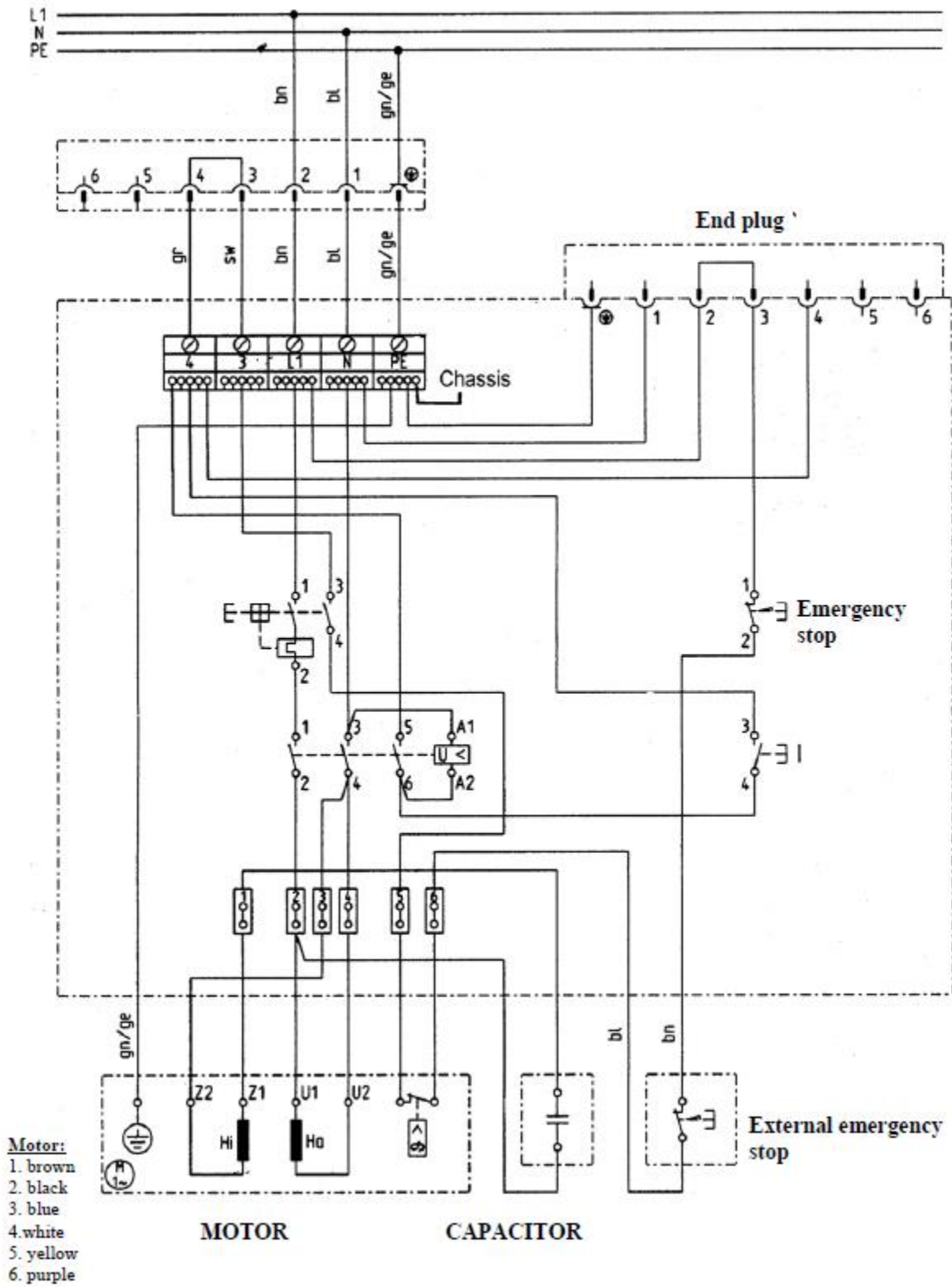

EMERGENCY STOP DIAGRAM

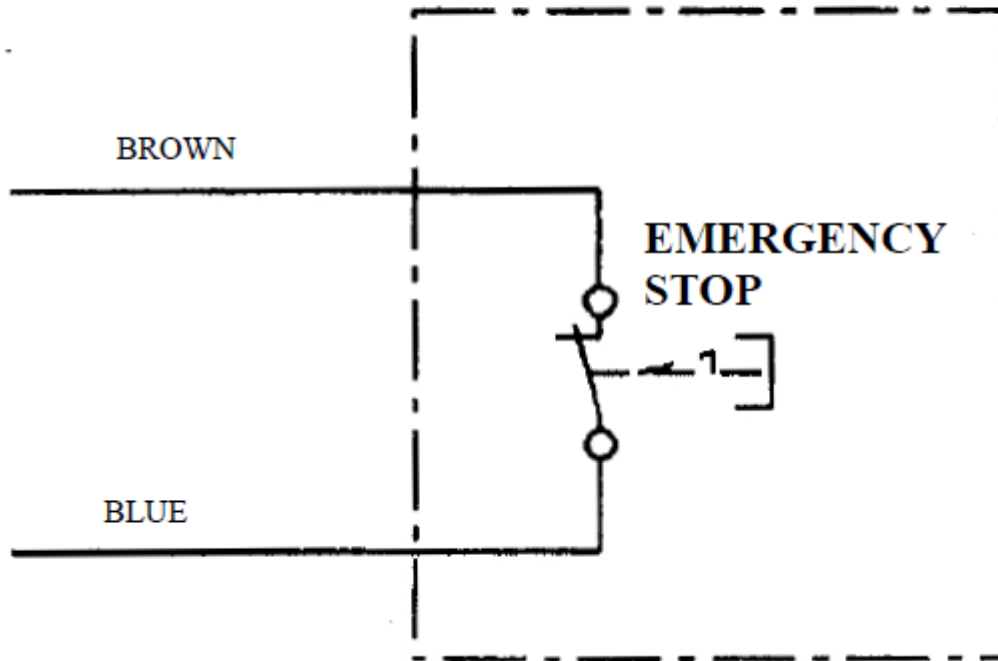



ALTRAX

Open Hours:
Monday – Friday
9am to 5pm

9 Milgate Street,
Oakleigh South, 3167

(03) 9808 9448

info@altrax.com.au

www.altrax.com.au